

Ezi-Actuator[®]

Hollow Rotary Belt-Driven Actuator

- Hollow Rotary Index Table
- Accurate Timing Belt Driven
- Low Cost But High Precision
- High Rigidity
- High Torque
- Easy to Use

HB



FASTTECH

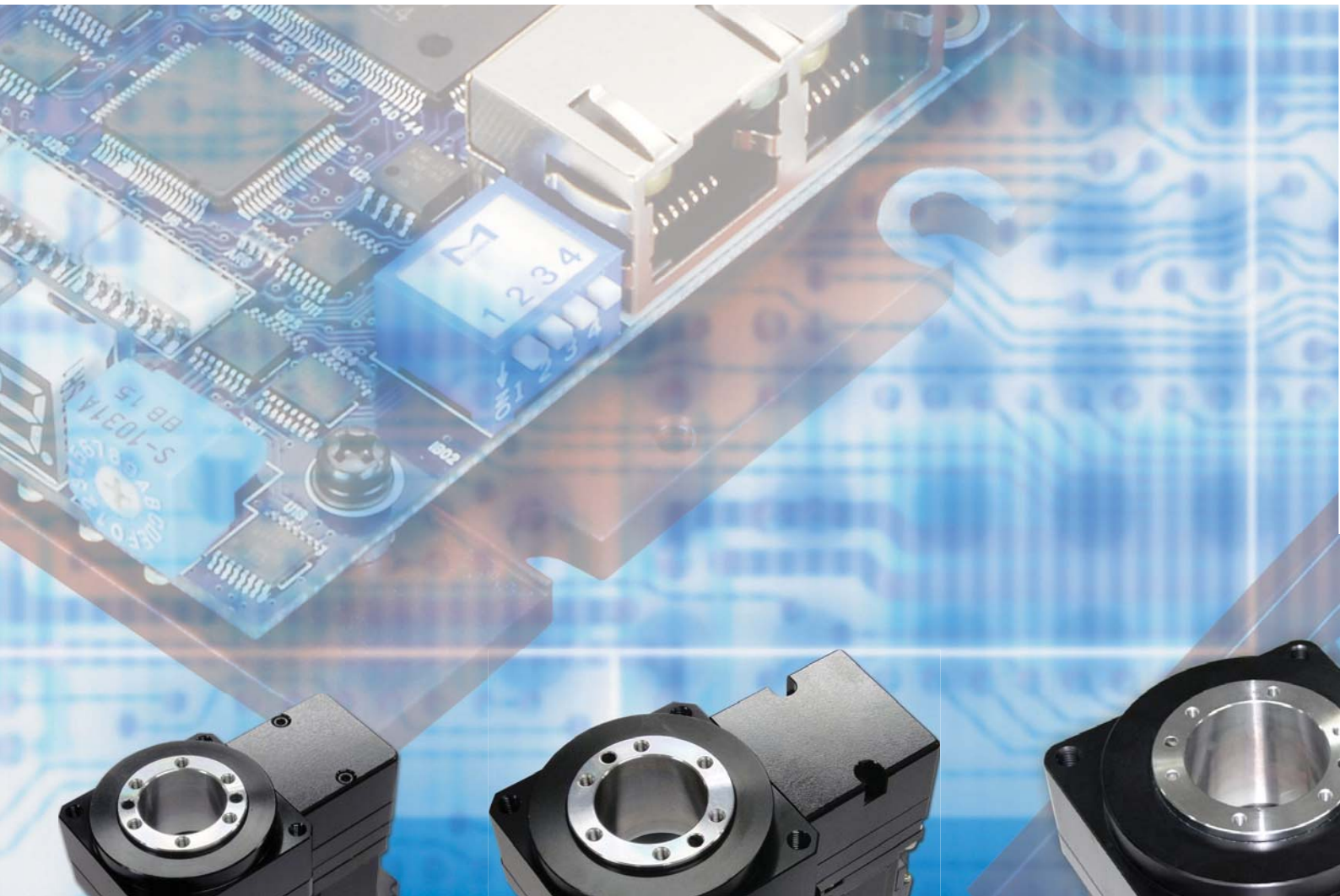

HB60

HB85

HB130



Ezi-Actuator[®] HB

Hollow Rotary Belt-Driven Actuator

High performance and Economical diffusion of Hollow Rotary Actuator, Ezi-Actuator HB Series, is extremely low back lash timing belt is driven into the hollow rotary table combines to high speed, high accuracy of closed loop stepping control system, Ezi-SERVO.



Hollow Rotary Table

Large diameter hollow bore to penetrate the output table equipped HB Series ensure flexibility and convenience in the design of equipment when install complex wiring and piping.



Model Name	Size of Plinth (Frame Size)	Hollow Bore Diameter
HB60	60mm	Φ27mm
HB85	85mm	Φ37mm
HB130	130mm	Φ55mm

Accurate Timing Belt Driven

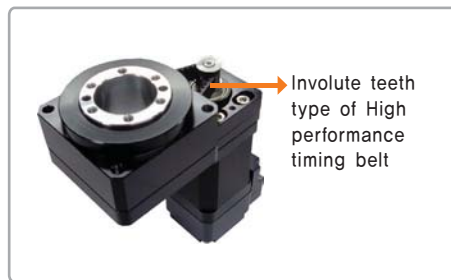

Extremely low backlash timing belt direct drive, so that repetitive positioning accuracy from single direction is +/-30sec and lost motion by positioning two directions for less than 6min and the precise positioning can be determined, Involute teeth type of timing belt enables Max. electric capacity and low noise operation.

High Rigidity

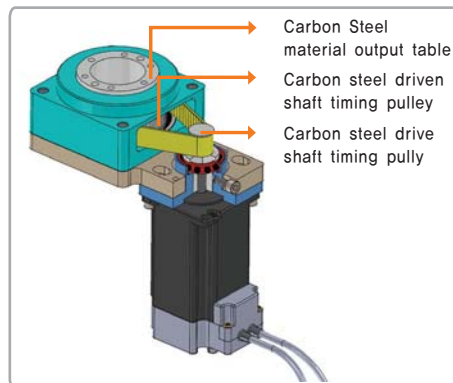

High rigidity of 2 Deep Groove Ball Bearing and hollow rotary table integrated HB Series maximizes allowable thrust load and moment load. Also high rigidity carbon steel timing pulley reinforce durability of abrasion and innovate durability.

Long and Durable Lifetime

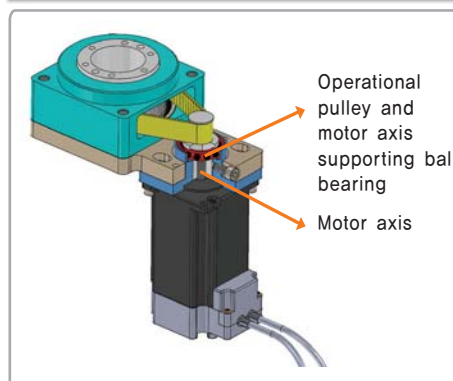

To solve most common fracture of the motor shaft at timing belt drive actuator, HB series dramatically improves endurance to resolve driven motor shaft's fatigue from the timing belt tension of the driven motor shaft fatigue with bearings firmly supports driven pulley directly coupled with motor shaft

Feature

Fast Response

High rigidity Rotary table fixed to the closed loop stepping control system, Ezi-SERVO can shorten positioning time for big inertia applications.

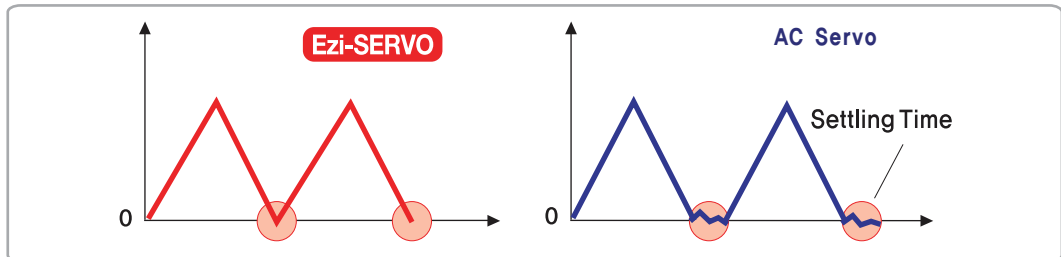

SUPPORTING SUDDEN LOAD FLUCTUATION AND RAPID ACCELERATION

Adopting a closed loop stepping control system, Ezi-SERVO designed to maintain synchronism and does not have step-out problem, Ezi-Actuator HB series can be driven by rapid acceleration or sudden load fluctuation because the situation in a typical servo system that is prone to fluctuation, Hunting does not occur. For sudden load fluctuation with a servo system is essential to improve the control performance does not need to gain adjustment is Gain Tuning Free Actuator

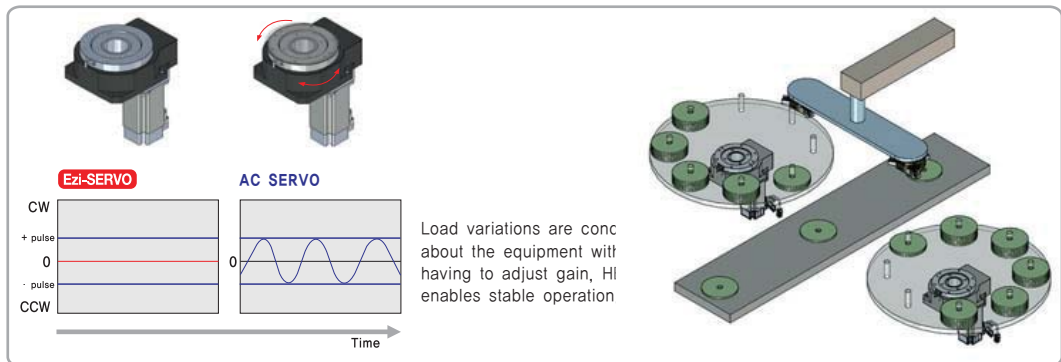

VARIETY OF CONTROLLER WITH HIGH PERFORMANCE AND MULTI-TASKING



Ezi-SERVO, high performance closed loop stepping control system by adopting, pulse train input drives and controller integrated drives are possible to use.

NETWORK BASED MULTI-AXES MOTION CONTROL

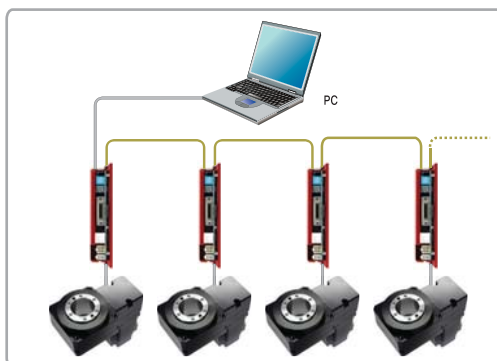

A maximum of 16 axes can be operated from a PC through RS-485 communications. All of the Motion conditions are set through the network and saved in Flash ROM as a parameter. Motion Library (DLL) is provided for programming under Windows 2000/XP.

POSITION TABLE FUNCTION

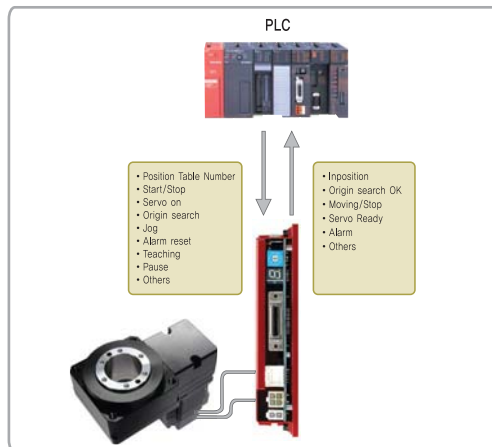

Position Table can be used for motion control by digital input and output signals of host controller. You can operate the motor directly by sending the position table number, start/stop, origin search and other digital input values from a PLC. The PLC can monitor The In-Position, origin search, moving/stop, servo ready and other digital output signals from a drive. A maximum of 256 positioning points can be set from PLC

EXTENSIVE INPUT/OUTPUT SIGNALS AND USER-DEFINED FUNCTIONS

Input 9 points/9 points signal output according to the needs of users can be defined. Therefore, various functions depending on the needs of the user input/output wiring must be used without changing.

Examples of Ezi-Actuator HB Applications

Applications support to changing load inertia fluctuation

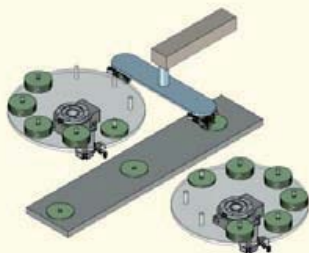

Applications for high precision positioning

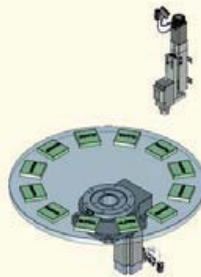

Applications support moment load

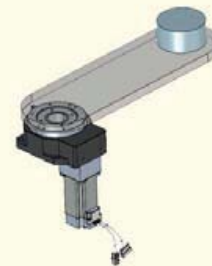

Applications for optical applications using hollow bore

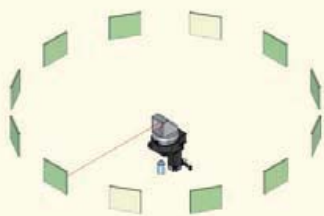

Applications for air absorption using hollow bore

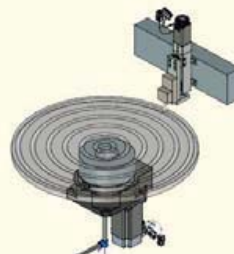

Applications for a precise positioning using hollow bore

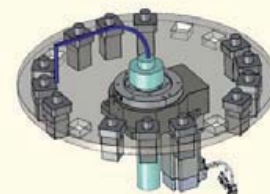

Number/Specifications and Outline

Ezi-Actuator HB Part Number

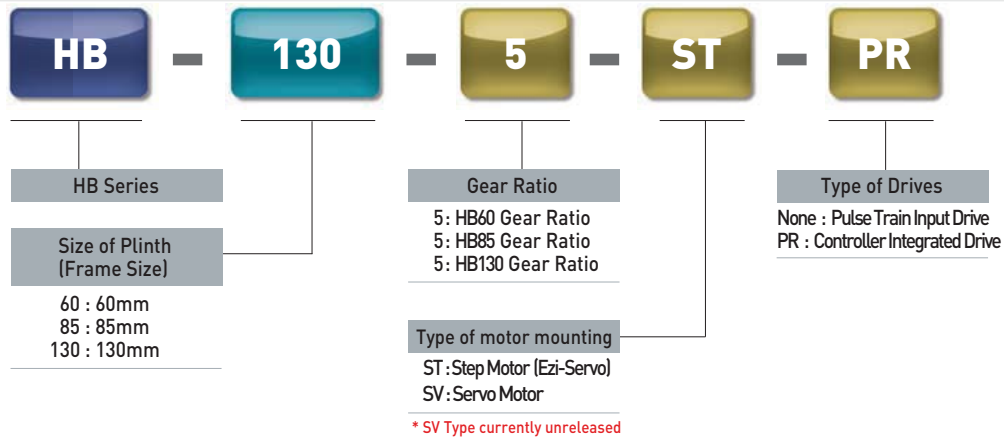

HOW TO READ THE SPECIFICATION

Part Number	HB60-05-ST	Part Number	HB60-05-ST
Type of Motor	Ezi-Servo 42XL Step Motor	⑩ Angular Transmission Error (min)	10
① Type of output table supporting bearing	Ball Bearing	⑪ Permissible Thrust Load (N)	100
② Permissible Torque (N · m)	2,7	⑫ Permissible Moment Load (N · m)	2
③ Inertial Moment J : (Kg · m ²)	500 x 10 ⁻⁷	⑬ Runout of output table surface (mm)	0,015
④ Permissible Speed (rpm)	300	⑭ Runout of output table inner/outer diameter (mm)	0,015
⑤ Gear Ratio	1:5	⑮ Runout of output table inner/outer diameter (mm)	0,03
⑥ Maximum Holding Torque (N · m)	1,3	⑯ Degree of protection	IP40 (IP20 for motor connector)
⑦ Resolution (ppr)	10,000	⑰ Mass (Kg)	1,2
⑧ Repetitive Positioning Accuracy (sec)	±30 (0,0083 °)		
⑨ Lost Motion (min)	6		

Show description of specification items

- ① Type of Output Table Supporting Bearing: The type of the bearing used for the output table.
- ② Permissible torque: The limit of mechanical strength of the reduction gear mechanism enables to make sure the applied torque including acceleration torque and load fluctuation and it will not exceed the permissible torque. Total sum of rotor inertia moment of the motor and the reduction gear of mechanism, converted to a moment on the output table.
- ③ Inertia moment: The output table speed can be tolerated by the mechanical strength of the reduction gear mechanism. Deceleration mechanism to configure the number of teeth of two gears.
- ④ Table Permissible Speed: Hollow Rotary actuator can exert the maximum holding torque once the actuator is at standstill with power supplied.
- ⑤ Gear ratio: Needed number of pulse to rotate 1 revolution of output table.
- ⑥ Maximum Holding Torque: A Value indicates the degree of error which is generated when positioning performs repeatedly to the same position in the same direction.
- ⑦ Resolution: The difference at the stopped angles achieved when the output table is positioned to the same position during forward and reverse direction of motions. And difference is mainly caused by backlash of gear. And this value calculated from the input pulse number.
- ⑧ Repetitive Positioning Accuracy: The permissible value of thrust load applied to the output table in the axial direction.
- ⑨ Lost Motion: When a load is applied to a position away from the center of the output table, the output table receives a tilting force and the permissible moment load refers to the permissible value of moment load calculated by multiplying the offset distance from the center by the applied load.
- ⑩ Angular transmission error: The maximum value of runout of the mounted surface of the output table when the output table rotates without load.
- ⑪ Permissible thrust load: The maximum value of runout of the inner diameter or outer diameter of the table when the output table rotates without load.
- ⑫ Permissible moment load: Actuator (plinth base) installed on the output side of the Table and value that indicates whether the degree inclines.
- ⑬ Runout of output table surface: IEC 60529, EN60034-5 (= IEC60034-5) classifies the dust resistance and waterproofing into grades.
- ⑭ Runout of output table inner/outer diameter: A sum of Actuator configured as the output Table, deceleration mechanism, such as driving motor plus the weight of all components.
- ⑮ Parallelism of Output Torque
- ⑯ Degree of Protection IP40 (IP20 for motor connector)
- ⑰ Mass

Specifications and Outline

HB85 SERIES SPECIFICATIONS



Part Number	HB85-5-ST	HB85-5-ST-PR
Type of motor	Ezi-Servo 56L Step Motor	Ezi-Servo 56L Step Motor
Type of output table supporting bearing	Ball Bearing	Ball Bearing
Permissible Torque (N · m)	7	7
Inertia moment J : (Kg · m ²)	3800×10^{-7}	3800×10^{-7}
Permissible speed (rpm)	300	300
Gear ratio	1:5	1:5
Maximum Holding Torque (N · m)	3.6	3.6
Resolution (ppr)	10,000	10,000
Repetitive Positioning Accuracy (sec)	$\pm 30 (0.0083^\circ)$	$\pm 30 (0.0083^\circ)$
Lost Motion (min)	6	6
Angular transmission error (min)	10	10
Permissible thrust load (N)	200	200
Permissible moment load (N · m)	3	3
Runout of output table surface (mm)	0.015	0.015
Runout of output table inner/outer diameter (mm)	0.015	0.015
Parallelism of output table (mm)	0.03	0.03
Degree of protection IP40 (IP20 for motor connector)	IP40 (IP20 for motor connector)	IP40 (IP20 for motor connector)
Mass (Kg)	3.1	3.1

HB85 SERIES SPECIFICATIONS

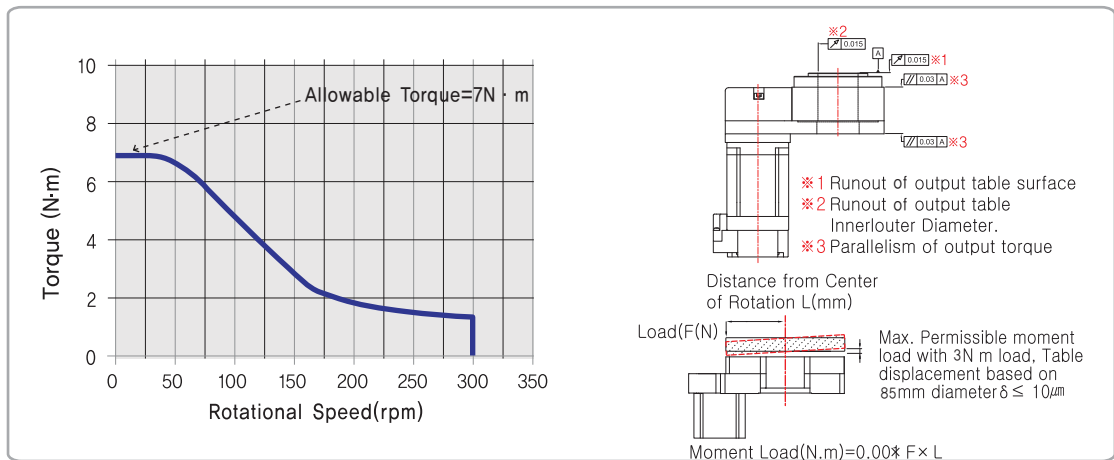

HB85 SERIES DIMENSIONS

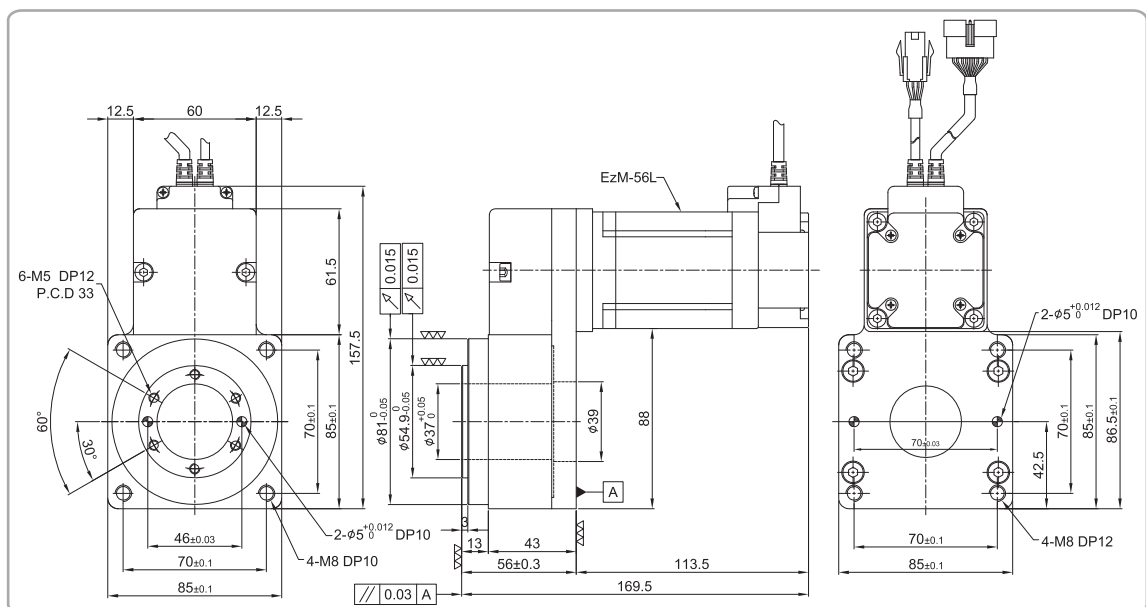

HB130 SERIES SPECIFICATIONS



Part Number	HB130-5-ST	HB130-5-ST-PR
Type of motor	-	Ezi-Servo 60L Step Motor
Type of output table supporting bearing	Ball Bearing	Ball Bearing
Permissible Torque (N · m)	12,8	12,8
Inertia moment J : (Kg · m ²)	15500 x 10 ⁻⁷	15500 x 10 ⁻⁷
Permissible speed (rpm)	300	300
Gear ratio	1:5	1:5
Maximum Holding Torque (N · m)	3,6	3,6
Resolution (ppr)	10,000	10,000
Repetitive Positioning Accuracy (sec)	±30 (0,0083 °)	±30 (0,0083 °)
Lost Motion (min)	6	6
Angular transmission error (min)	10	10
Permissible thrust load (N)	500	500
Permissible moment load (N · m)	5	5
Runout of output table surface (mm)	0,015	0,015
Runout of output table inner/outer diameter (mm)	0,015	0,015
Parallelism of output table (mm)	0,03	0,03
Degree of protection IP40 (IP20 for motor connector)	IP40 (IP20 for motor connector)	IP40 (IP20 for motor connector)
Mass (Kg)	4,0	4,0

HB130 SERIES SPECIFICATIONS

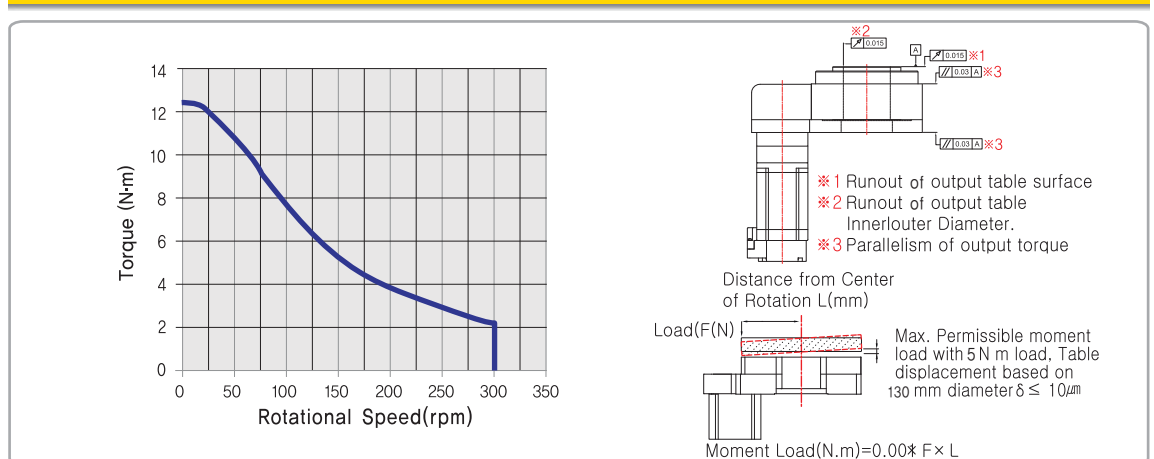

HB130 SERIES DIMENSIONS

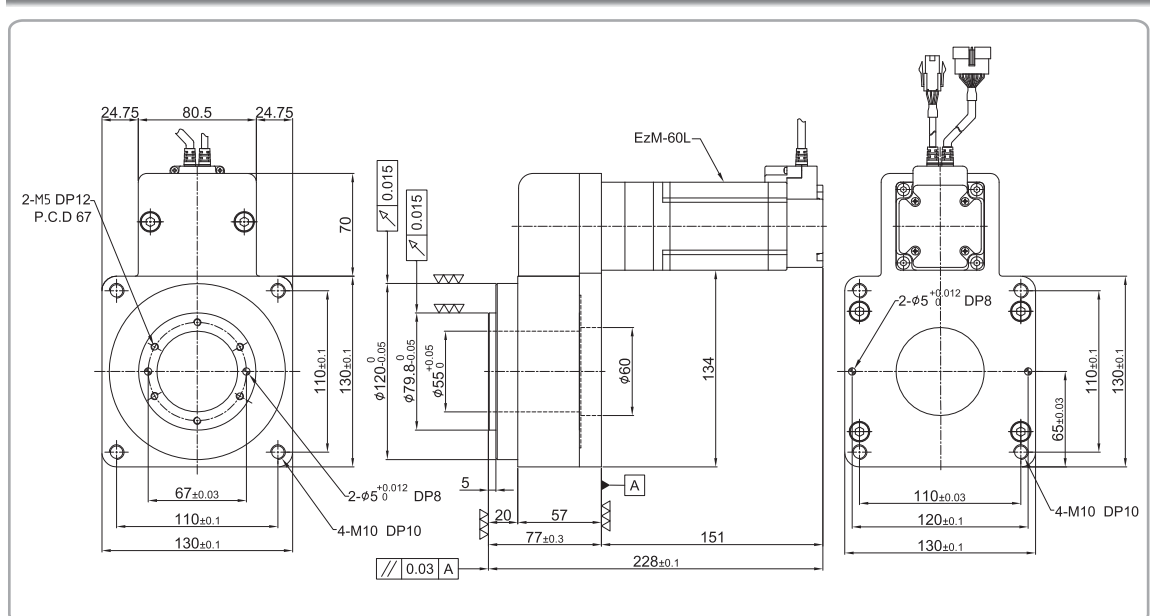

Mechanism Option

HOME-SENSOR SET

Rotary table drive less frequently required to perform homing Photo Micro Sensor, Connector Attach Cable, blue filter, install the screws to Set Sensor Set the origin has been established as an option, There needed to detect the origin because the origin of all parts of the installation when necessary Sensor takes part in designing, manufacturing and parts procurement to relieve the trouble, it also can be used to install easily.

■ 종류

Model	Sensor output	Applicable Product
OSHB-A	NPN	HB60, HB85, HB130
OSHB-AY	PNP	

■ Home-Sensor Set Composition OSHB-A



■ Specifications

Type	NPN Type	PNP Type
Sensor Model	EE-SX672A (OMRON Product) HB60, HB85, HB130 common	EE-SX672A (OMRON Product) HB60, HB85, HB130 common
Supply voltage	DC5~24V±10%, Ripple (P-P) 10% less	DC5~24V±10%, Ripple (P-P) 10% less
Current consumption	35mA less	30mA less
Control Output	NPN Open Collector output DC5~24V 100mA less Residual Voltage 0.8V or less (at load current of 100mA)	NPN Open Collector output DC5~24V 50mA less Residual Voltage 1.3V or less (at load current of 50mA)
Indicator LED	Detection Display (RED)	Detection Display (RED)
Sensor Logic	Normally Open/Normally Closed (Switchable, depending on connection)	Normally Open/Normally Closed (Switchable, depending on connection)

■ Connector attached Cable (OMRON Robot code attached connector EE1010-R)



Terminal Layout

①	⊕	Brown
②	L	Pink
③	OUT	Black
④	⊖	Blue

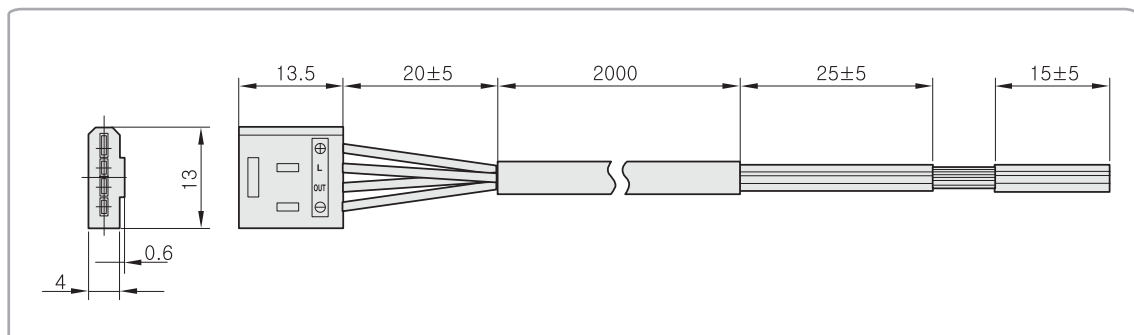

Notes for sensor set of installation

Option to install is the origin sensor set pay attention to the following.

- Use the temperature below 40°C, Motor Part surface temperature 90°C or less, to be sure to set operating conditions.
- Please prepare individual sensor and bracket to get homing with using from motor shaft. Notes for sensor lines is extended. Sensor shield should be cabled and grounded if extended to more than 2 Meter long.

Notes for sensor lines is extended.

Sensor shield should be cabled and grounded if extended to more than 2 Meter long.

 DIMENSIONS OF HOME-SENSOR INSTALLATION

■ HB60

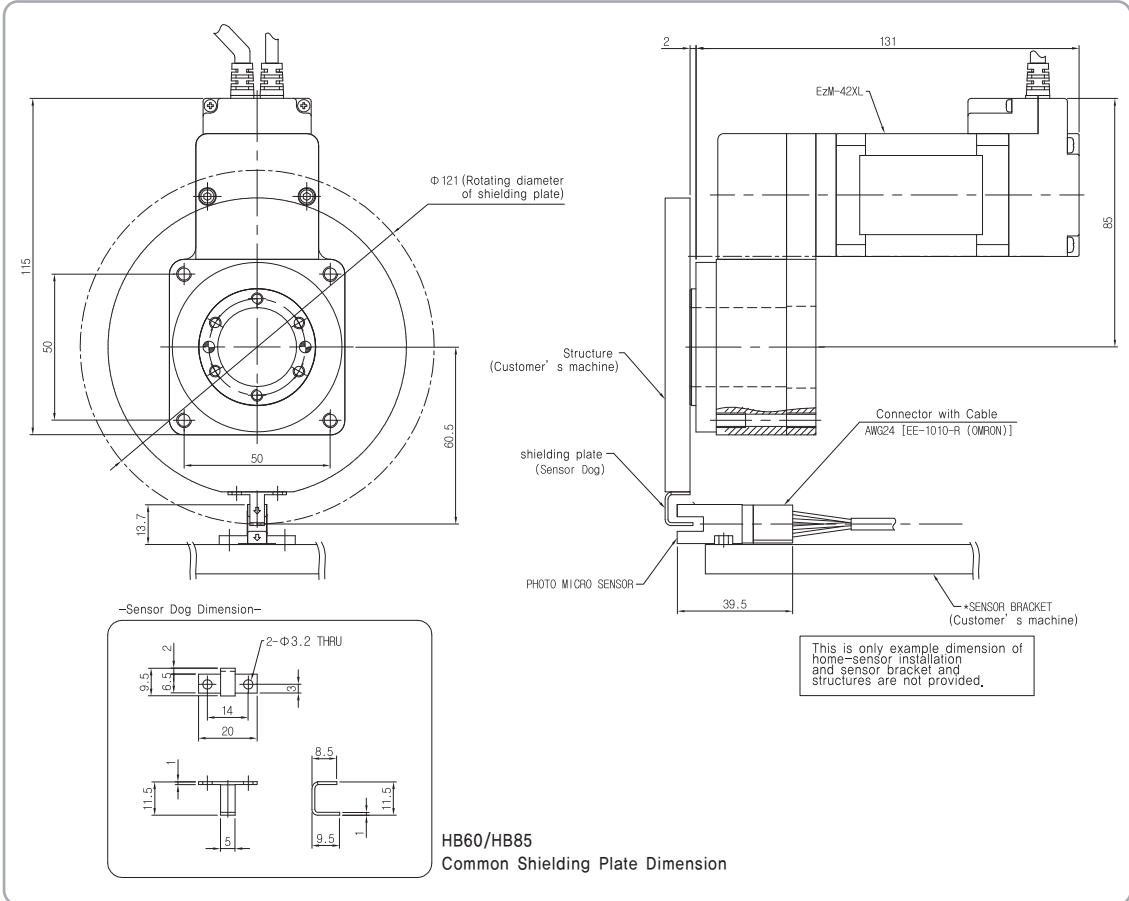

■ HB85

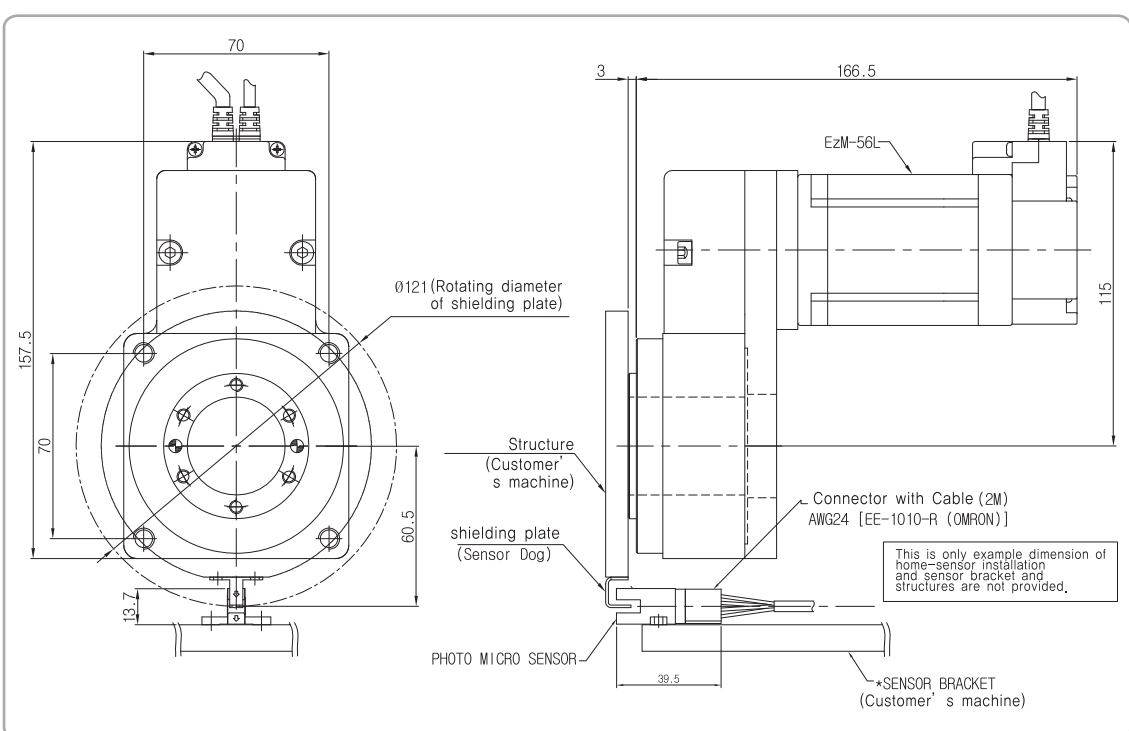

Mechanism Option

☑ DIMENSIONS OF HOME-SENSOR INSTALLATION

■ HB130

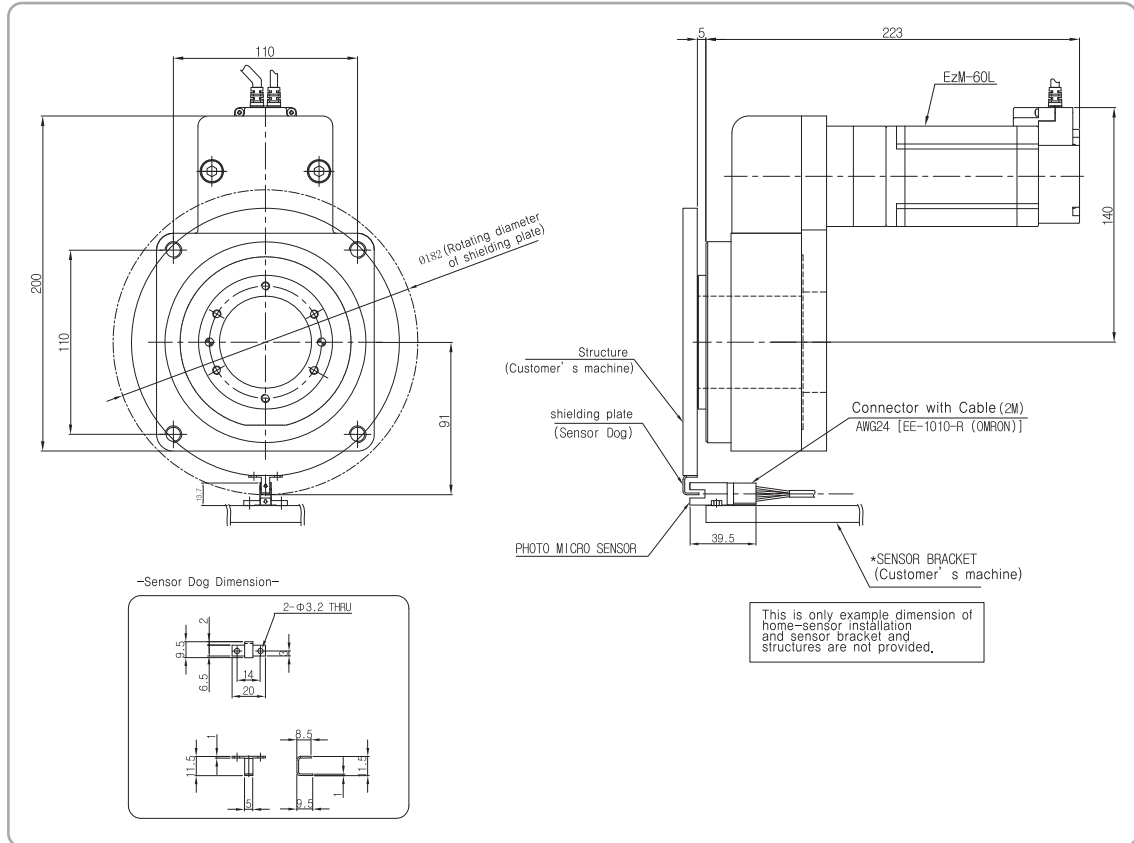

DIMENSIONS OF HOME-SENSOR INSTALLATION

■ NPN Type

Please use DC 5V, DC 24V power supply or less and consult the current value less than 100mA. If more than 100mA, please connect external register R. And sensor power supply and user controller power supply GND should be a common.

- Pulse train input unit

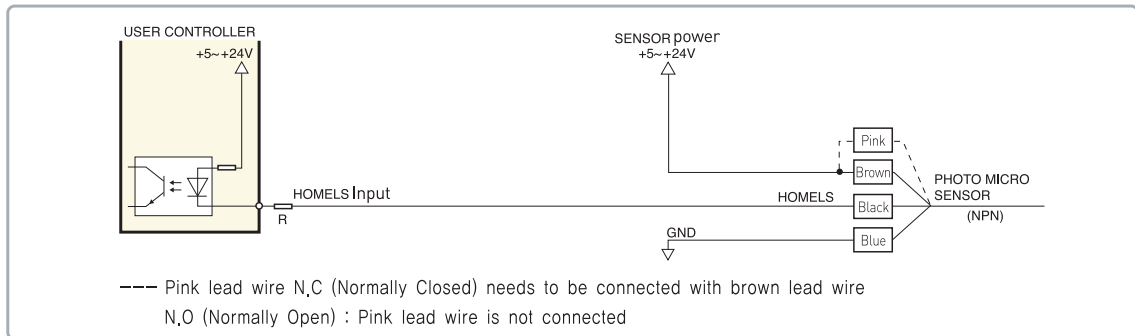

- Controller integrated unit

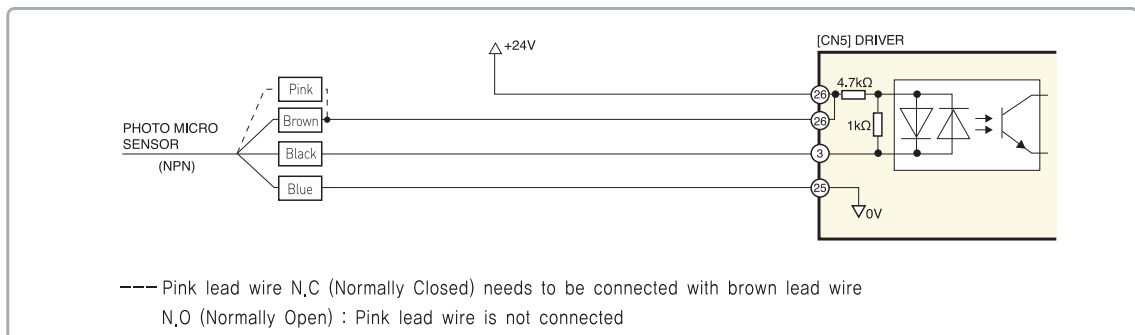

■ PNP Type

Please use DC 5V, DC power supply or less and consult the current value less than 100mA. If more than 50mA, please connect external register R.

- Pulse train input unit

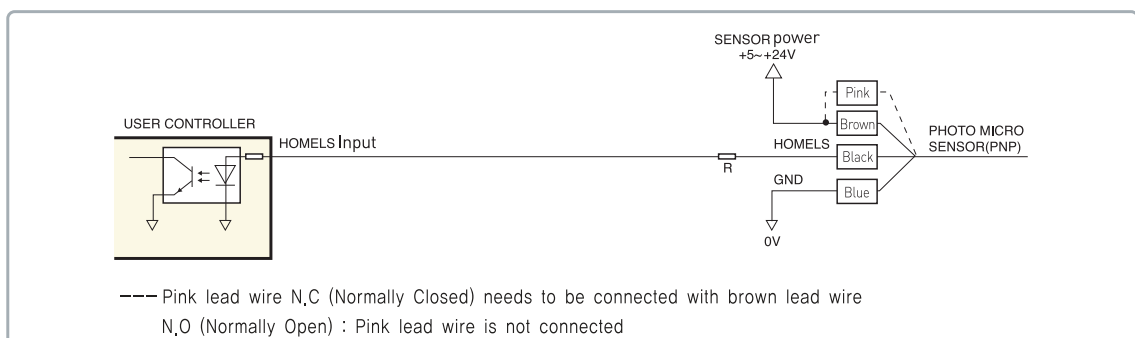

- Controller integrated unit

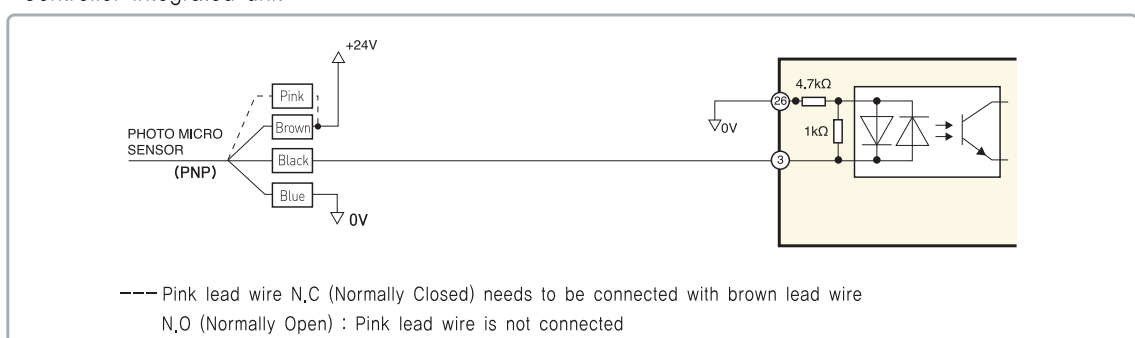

PRODUCT INSTALLATION GUIDE

Ezi-Actuator HB Installation Guide

For HB Series application, please refer to following pictures and installation guidelines about setting-plate

■ Installation guides based on setting plate (In case of TAP Hole already processed onto setting plate)

▪ Installation Bolt Standard

Model	Standard
HB60	M4 X 40L
HB85	M6 X 50L
HB130	M8 X 65L

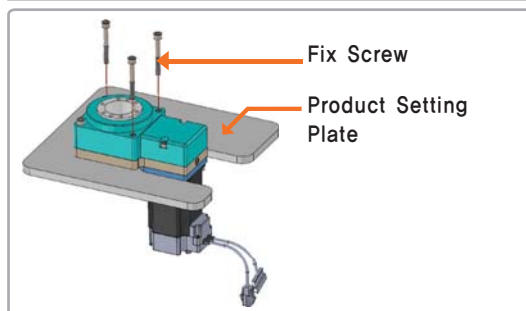

■ Installation guides with using TAP underneath surface of Actuator

▪ Installation Bolt Standard

Model	Standard
HB60	M5 X 10L
HB85	M8 X 10L
HB130	M10 X 10L

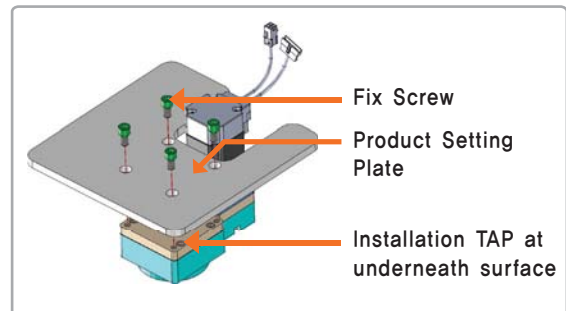

※ Please refer to the table for product installation Bolt.
Please use recommended standard Bolt to prevent product damage from using non-standard Bolt.

■ Actuator Pilot Based Installation Guides

▪ Installation Bolt Standard

Model	Standard
HB60	M5 X 10L
HB85	M8 X 10L
HB130	M10 X 10L

▪ Installation Pilot Standard

Model	Standard
HB60	$\phi 58^{0}_{-0.05}$
HB85	$\phi 81^{0}_{-0.05}$
HB130	$\phi 120^{0}_{-0.05}$

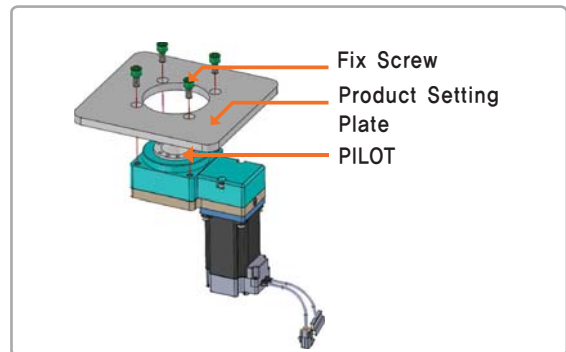

■ Work Installation guides on output table

- Please fix Work by Bolt at 6 positions of TAP Hole on output table
- Prepared 2 Pin Holes at Output table to set Work (Please use for accurate positioning)
- Please attach positioning pin at Pin Hole of Work in order to use Output Table Work Installation purpose Pin Hole.

▪ Positioning Pin Hole

Model	Standard	Pin Hole
HB60	$\phi 40^{+0.012}_{-}$ Depth8	2
HB85	$\phi 50^{+0.012}_{-}$ Depth10	
HB130	$\phi 50^{+0.012}_{-}$ Depth8	

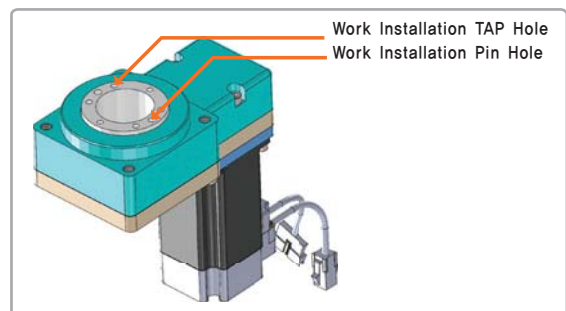

Drive and Motor Combination

☑ PULSE INPUT DRIVE AND MOTOR COMBINATION

Unit Model Number	Motor Model Number	Drive Model Number
HB60-5-ST	EzM-42XL-A-D	EzS-PD-42XL-A
HB85-5-ST	EzM-56L-A-D	EzS-PD-60L-A
HB130-5-ST	EzM-60L-A-D	EzS-PD-60L-A



☑ CONTROLLER EMBEDDED DRIVE AND MOTOR COMBINATION

Unit Model Number	Motor Model Number	Drive Model Number
HB60-5-ST-PR	EzM-42XL-A-D	EzS-NDR-42XL-A
HB85-5-ST-PR	EzM-56L-A-D	EzS-NDR-60L-A
HB130-5-ST-PR	EzM-60L-A-D	EzS-NDR-60L-A



Pulse Input Drive

SPECIFICATIONS OF PULSE INPUT DRIVE

Motor Model	EzM-42 series	EzM-56 series	EzM-60 series
Driver Model	EzS-PD-42 series	EzS-PD-56 series	EzS-PD-60 series
Input Voltage	24VDC±10%		
Control Method	Closed loop control with 32bit DSP		
Current Consumption	Max 500mA (Except motor current)		
Operating Condition	Ambient Temperature	In Use : 0~50°C In Storage : -20~70°C	
	Humidity	In Use : 35~85% (Non-Condensing) In Storage : 10~90% (Non-Condensing)	
	Vib. Resist.	0,5G	
Function	Rotation Speed	0~3,000rpm	
	Resolution(P/R)	10,000/Rev. Encoder model: 500 1,000 1,600 2,000 3,600 5,000 6,400 7,200 10,000	
	Max. Input Pulse Frequency	500KHz (Duty 50%)	
	Protection Functions	Over current, Over speed, Position tracking error, Over load, Over temperature, Over regenerated voltage, Motor connect error, Encoder connect error, Motor voltage error, In-Position error, System error, ROM error, Position overflow error	
	LED Display	Power status, Alarm status, In-Position status, Servo On status	
	In-Position Selection	0~F (Selectable with DIP switch)	
	Position Gain Selection	0~F (Selectable with DIP switch)	
	Pulse Input Method	1-Pulse / 2-Pulse (Selectable with DIP switch)	
	Rotational Direction	CW / CCW (Selectable with DIP switch)	
	Speed/Position Control Command	Pulse train input	
I/O Signal	Input Signals	Position command pulse, Servo On/Off, Alarm reset (Photocoupler input)	
	Output Signals	In-Position, Alarm (Photocoupler output) Encoder signal (A+, A-, B+, B-, Z+, Z-, 26C31 of Equivalent) (Line Driver output)	

DIMENSION OF PULSE INPUT DRIVE (mm)

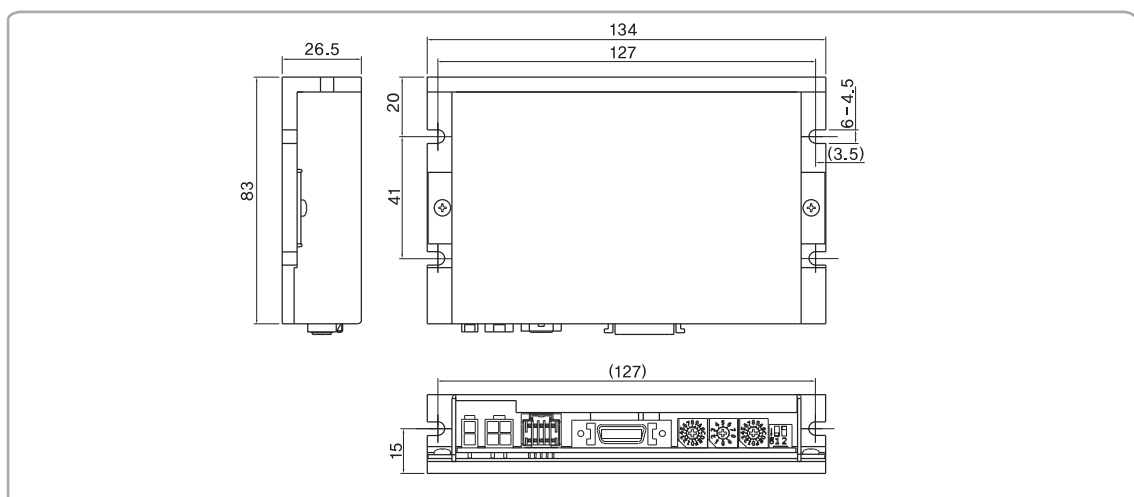

Controller Embedded Drive

SPECIFICATIONS OF CONTROLLER EMBEDDED DRIVE

Motor Model	EzM-42 series	EzM-56 series	EzM-60 series
Driver Model	EzS-NDR-42 series	EzS-NDR-56 series	EzS-NDR-60 series
Input Voltage	24VDC \pm 10%		
Control Method	Closed loop control with 32bit DSP		
Multi Axes Drive	Maximum 16 axes through Daisy-Chain		
Position Table	256 motion command steps (Continuous, Wait, Loop, Jump and External start etc.)		
Current Consumption	Max 500mA (Except motor current)		
Operating Condition	Ambient Temperature	In Use : 0~50°C In Storage : -20~70°C	
	Humidity	In Use : 35~85% (Non-condensing) In Storage : 10~90% (Non-condensing)	
	Vib. Resist.	0.5G	
Function	Rotation Speed	0~3,000rpm	
	Resolution(P/R)	10,000/Rev. Encoder model : 500 1,000 1,600 2,000 3,600 5,000 6,400 7,200 10,000	
	Protection Functions	Over current, Over speed, Position tracking error, Over load, Over temperature, Over regenerated voltage, Motor connect error, Encoder connect error, Motor voltage error, In-Position error, System error, ROM error, Input voltage error, Position overflow error	
	LED Display	Power status, Alarm status, In-Position status, Servo On status	
	In-Position Selection	0~15 (Selectable by parameter)	
	Position Gain Selection	0~15 (Selectable by parameter)	
	Rotational Direction	CW / CCW (Selectable by parameter)	
I/O Signal	Input Signal	3 dedicated input (LIMIT+, LIMIT-, ORIGIN), 9 programmable input (Photocoupler)	
	Output Signal	1 dedicated output (Compare Out), 9 programmable output (Photocoupler), Brake signal	
Communication Interface	The RS-485 serial communication with PC Transmission speed : 9,600~921,600bps		
Position Control	Incremental mode / Absolute mode Data Range : -134,217,727 to +134,217,727pulse, Operating speed : Max. 3,000rpm		
Return to Origin	Origin Sensor, Z phase, \pm Limit sensor, Torque		
GUI	User Interface Program within Windows		
Software	Motion Library (DLL) for windows 2000/XP		

DIMENSION OF CONTROLLER EMBEDDED DRIVE (mm)

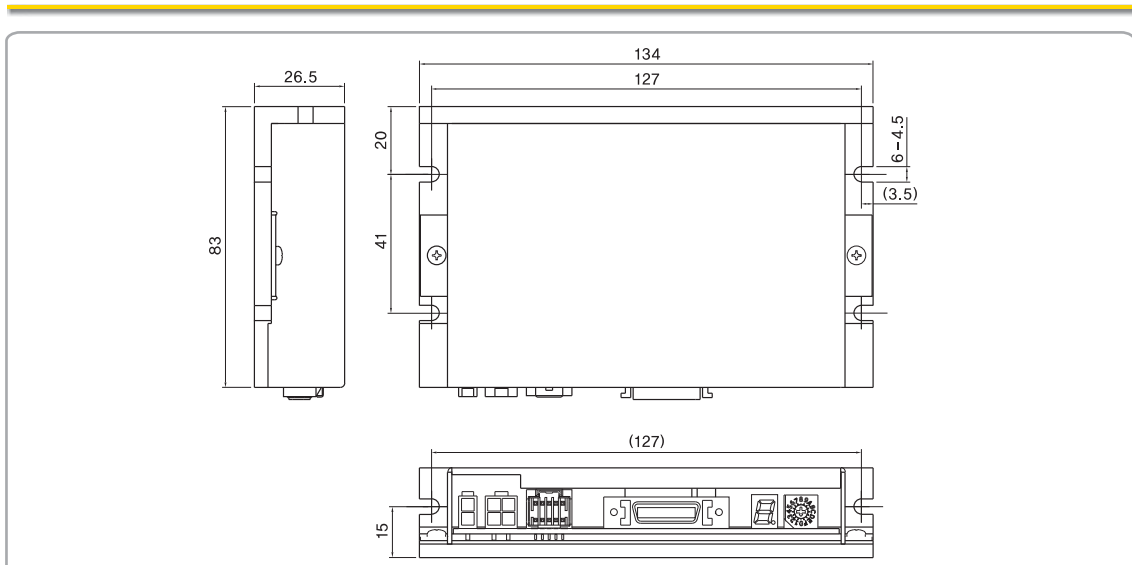

Motor Specifications and Torque Characteristics

SPECIFICATIONS OF MOTOR (SAME FOR PULSE INPUT AND CONTROLLER EMBEDDED DRIVE)

Model	Unit	EzM-42XL-A	EzM-56L-A	EzM-60L-A
Drive Method	-	Bi-Polar	Bi-Polar	Bi-Polar
Number of Phase	-	2	2	2
Voltage	VDC	7,2	2,7	2,6
Current per Phase	A	1,2	3	4
Resistance per Phase	Ohm	6	0,9	0,65
Inductance per Phase	mH	15,6	3,8	2,4
Holding Torque	N · m	0,8	1,5	2,4
Rotor Inertia	g · cm	114	480	800
Weight	g	500	1150	1600
Length	mm	59	80	90
Allowable Thrust Load	N	Lower than motor weight		
Insulation Resistance	Mohm	100min (at 500VDC)		
Insulation Class	-	Class B		
Operating Temperature	° C	0 to 55		

MOTOR TORQUE CHARACTERISTICS (SAME FOR PULSE INPUT AND CONTROLLER EMBEDDED DRIVE)

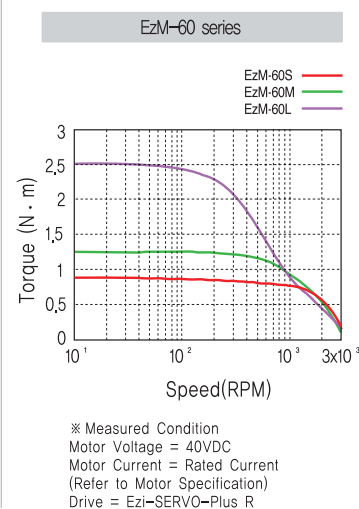
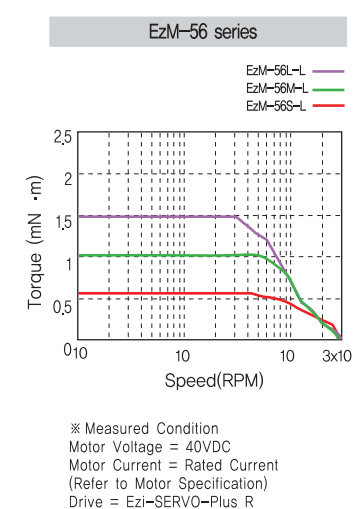
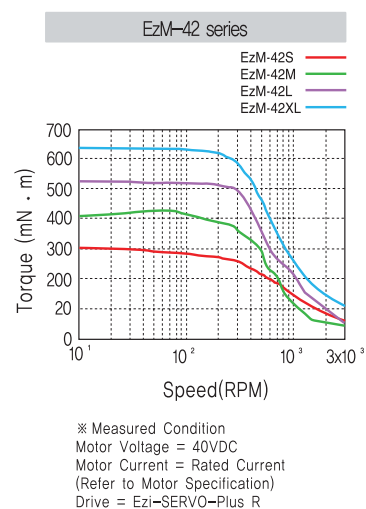
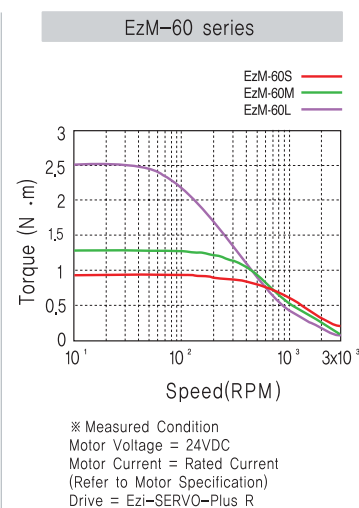
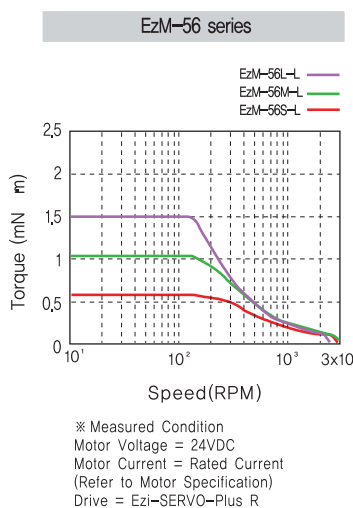
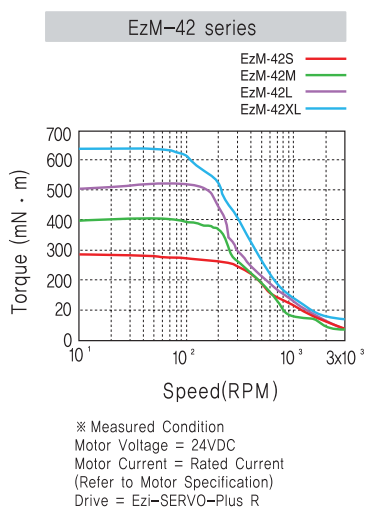

Pulse Input Drive Setting and Operating

📷 PULSE INPUT DRIVE SETTING AND OPERATING

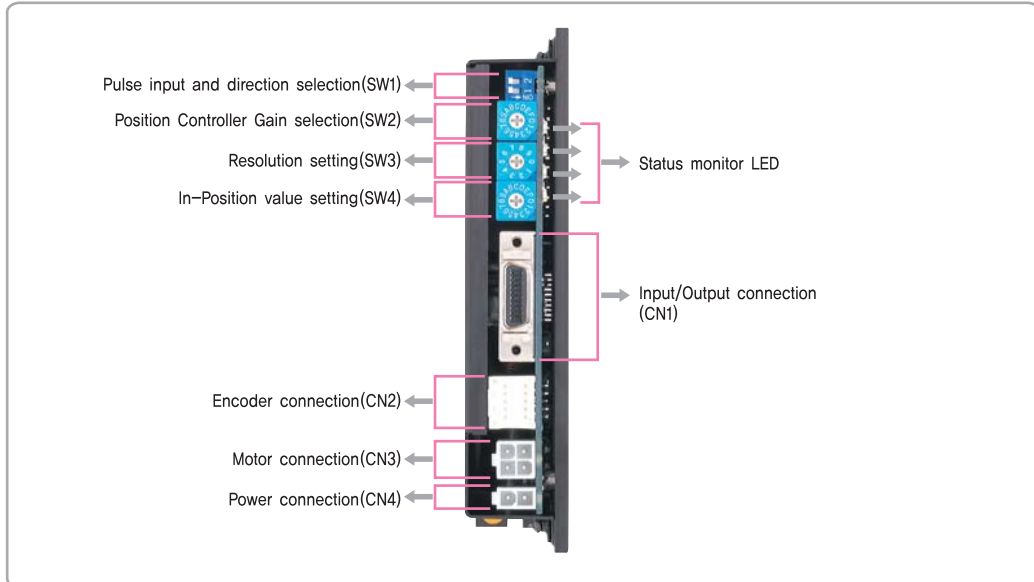

📷 SETTING AND OPERATING

■ Status Monitor LED

Indication	Color	Function	ON/OFF Condition
PWR	Green	Power input indication	LED is turned ON when power is applied
INP	Yellow	Complete Positioning Motion	Lights On when Positioning error reaches within the preset pulse selected by rotary switch
SON	Orange	Servo On/Off Indication	Servo On : Lights On Servo Off : Lights Off
ALM	Red	Alarm indication	Flash when protection function is activated (Identifiable which protection mode is activated by counting the blinking times)

• Protection functions and LED flash times

Times	Protection	Conditions
1	Over current	The current through power devices in inverter exceeds the limit value
2	Over speed	Motor speed exceed 3000rpm
3	Step out	Position value is higher than specified value in motor stop status
4	Over load	The motor is continuously operated more than 5 second under a load exceeding the max. torque
5	Over temperature	Inside temperature of drive exceeds 55 °C
6	Over regenerated voltage	Back-EMF more high limit value ^{*1}
7	Motor Connect error	The power is ON without connection of the motor cable to drive
8	Encoder Connect error	Cable connection error with Encoder connector in drive
9	Low input voltage	Power source voltage is below limited value ^{*2}
10	Inposition error	After operation is finished,a position error occurs
11	System error	Error occurs in drive system
12	ROM error	Error occurs in parameter storage device(ROM)
14	Hight input voltage	Power source voltage is higher than limited value ^{*3}

^{*1} Voltage limit of Back-EMF depends on motor model (Refer to the Manual)

^{*2} Low limit voltage value depends on motor model (Refer to the Manual)

^{*3} Limit value provided to drives depends on driver model (Refer to the Manual)

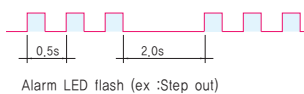

Alarm LED flash (ex :Step out)

Pulse Input Drive Setting and Operating

SETTING AND OPERATING

■ Pulse input and motor direction selection switch(SW1)

Indication	Switch Name	Functions
2P/1P (pin #1)	Selecting pulse input mode	Selectable 1-Pulse input mode or 2-Pulse input mode as Pulse input signal. ON : 1-Pulse mode / OFF :2-Pulse mode ※ Default : 2-Pulse mode
DIR (pin #2)	Switching Rotational Direction	Based on CW(+Dir signal)input to driver. ON : CCW(-Direction) / OFF : CW(+Direction) ※ Default : CW mode

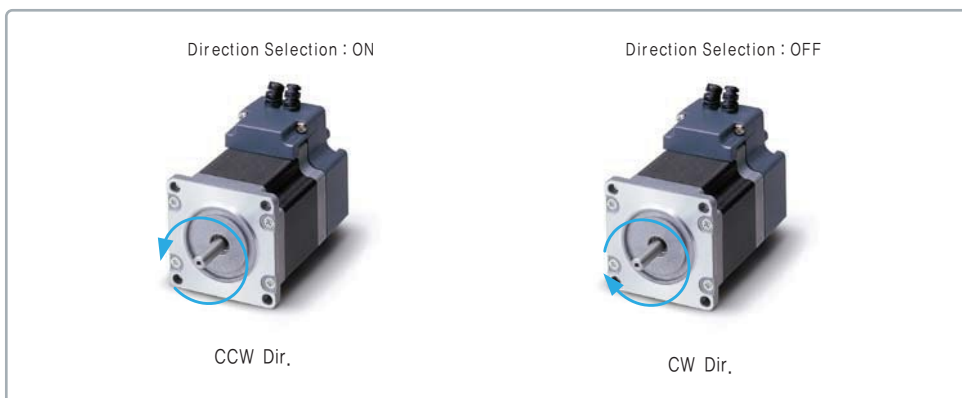

■ Position Controller Gain Selection switch(SW2)

The Position Controller Gain Switch allows for the correction of the motor position deviation after stopping caused by load and friction. Depending on the motor load, the user may have to select a different gain position to stabilize and to correct positional error quickly.

To tune the controller

1. Set the switch to "0" Position,
2. Start to rotate the switch until system becomes stable,
3. Rotate the switch +/- 1 ~ 2 position to reach better performance.

Position	Time Constant of the Integral part	Proportional Gain ^{*1}
0	1	1
1	1	2
2	1	3
3	1	4 ^{*2}
4	1	5
5	1	6
6	2	1
7	2	2
8	2	3
9	2	4
A	2	5
B	3	1
C	3	2
D	3	3
E	3	4
F	3	5



*1 Value in the columns are in relative units. They only show the parameter changes depending on the switch's position.

*2 Default =4

■ Resolution selection switch (SW3)

The Number f pulse per revolution.

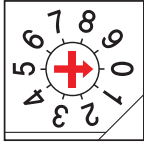

Position	Pulse/Rotation	Position	Pulse/Rotation
0	500*1	5	3600
1	500	6	5000
2	1000	7	6400
3	1600	8	7200
4	2000	9	10000*2

*1 Position '0' Resolution Value Depends on Encodertype, when use 16000, 20000, 32000 Resolution Encoder, Resolution sets as 16000, 20000, 32000
 *2 Default = 10,000

■ Position Value Setting switch(SW4)

To select the output condition of In-position signal, In-position output signal is generated when the pulse number of positional error is lower than selected In-position value set by this switch after positioning command is executed.

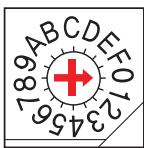

Position	In-Position Value [Pulse]Fast Response	Position	In-Position Value [Pulse]Accurate Response
0	0*1	8	0
1	1	9	1
2	2	A	2
3	3	B	3
4	4	C	4
5	5	D	5
6	6	E	6
7	7	F	7

*1 Default =0 * Please refer to User Manual for setup.

■ Motor Connector(CN3)



NO.	Function
1	A Phase
2	B Phase
3	/A Phase
4	/B Phase

■ Power Connector(CN4)



NO	Function
1	24VDC ±10%
2	GND

Pulse Input Drive Setting and Operating

SETTING AND OPERATING

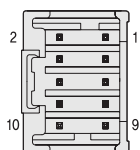

Encoder connector(CN2)

NO.	Function	I/O
1	A+	Input
2	A-	Input
3	B+	Input
4	B-	Input
5	Z+	Input
6	Z-	Input
7	5VDC	Output
8	5VDC GND	Output
9	Frame GND	-
10	Frame GND	-

Input / Output signal(CN1)

NO.	Function	I/O
1	CW+(Pulse+)	Input
2	CW-(Pulse-)	Input
3	CCW+(Dir+)	Input
4	CCW-(Dir-)	Input
5	A+	Output
6	A-	Output
7	B+	Output
8	B-	Output
9	Z+	Output
10	Z-	Output
11	Alarm	Output
12	In-Position	Output
13	Servo On/Off	Input
14	Alarm Reset	Input
15	NC	-
16	BRAKE+	Output
17	BRAKE-	Output
18	S-GND	Output
19	24VDC GND	Input
20	24VDC	Input

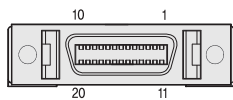

* BRAKE function is optional

Pulse Input Drive Setting and Operating

SYSTEM CONFIGURATION OF PULSE INPUT DRIVE

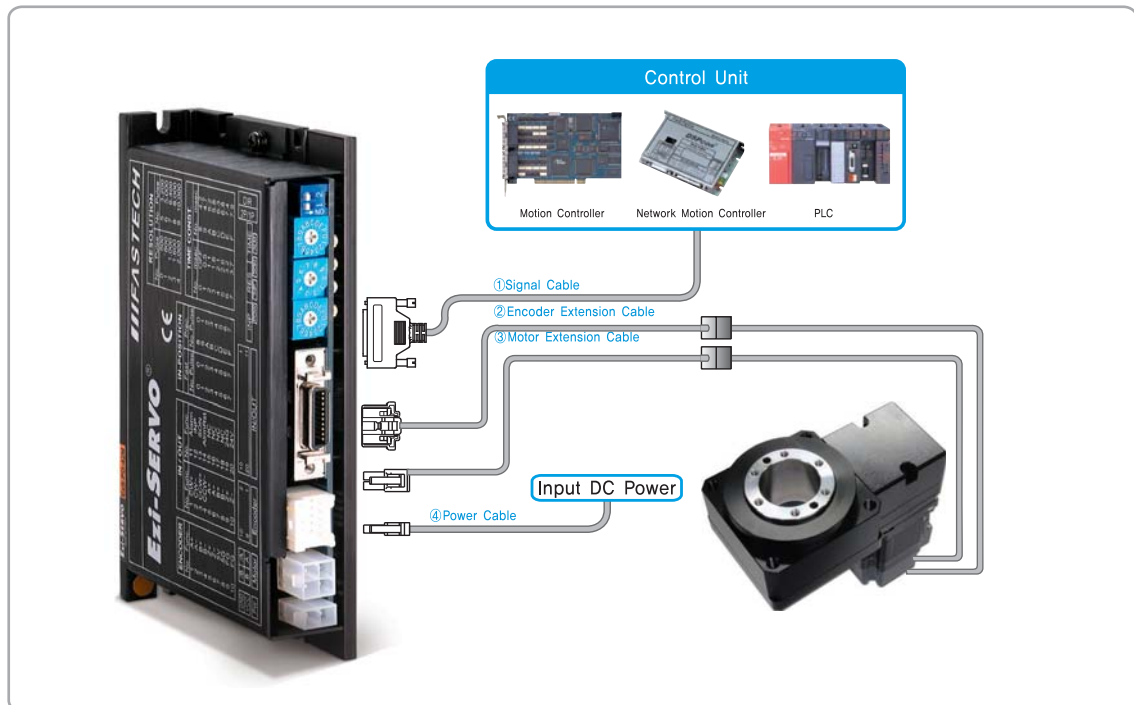

Type	Power Cable	Motor Cable	Encoder Cable	Signal Cable
Standard Length	–	30cm	30cm	–
Max.Length	2m	20m	20m	20m

■ Cable Option

1. Signal Cable

Available to connect between Control System and Ezi-SERVO

Item	Length [m]	Remark
CSVO-S-□□□F	□□□	고정형 케이블
CSVO-S-□□□M	□□□	가동형 케이블

□ is for Cable Length, The unit is 1m and Max. 20m length.

2. Encoder Extension Cable

Available to extended connection between Encoder and Ezi-SERVO.

Item	Length [m]	Remark
CSVO-E-□□□F	□□□	고정형 케이블
CSVO-E-□□□M	□□□	가동형 케이블

□ is for Cable Length, The unit is 1m and Max. 20m length.

3. Motor Extension Cable

Available to extended connection between motor and Ezi-SERVO.

Item	Length [m]	Remark
CSVO-M-□□□F	□□□	고정형 케이블
CSVO-M-□□□M	□□□	가동형 케이블

□ is for Cable Length, The unit is 1m and Max. 20m length.

4. Power Cable

Available to connect between Power and Ezi-SERVO

Item	Length [m]	Remark
CSVO-P-□□□F	□□□	고정형 케이블
CSVO-P-□□□M	□□□	가동형 케이블

□ is for Cable Length, The unit is 1m and Max. 2m length.

Pulse Input Drive Setting and Operating Control I/O Signals

PULSE INPUT DRIVE EXTERNAL WIRING DIAGRAM

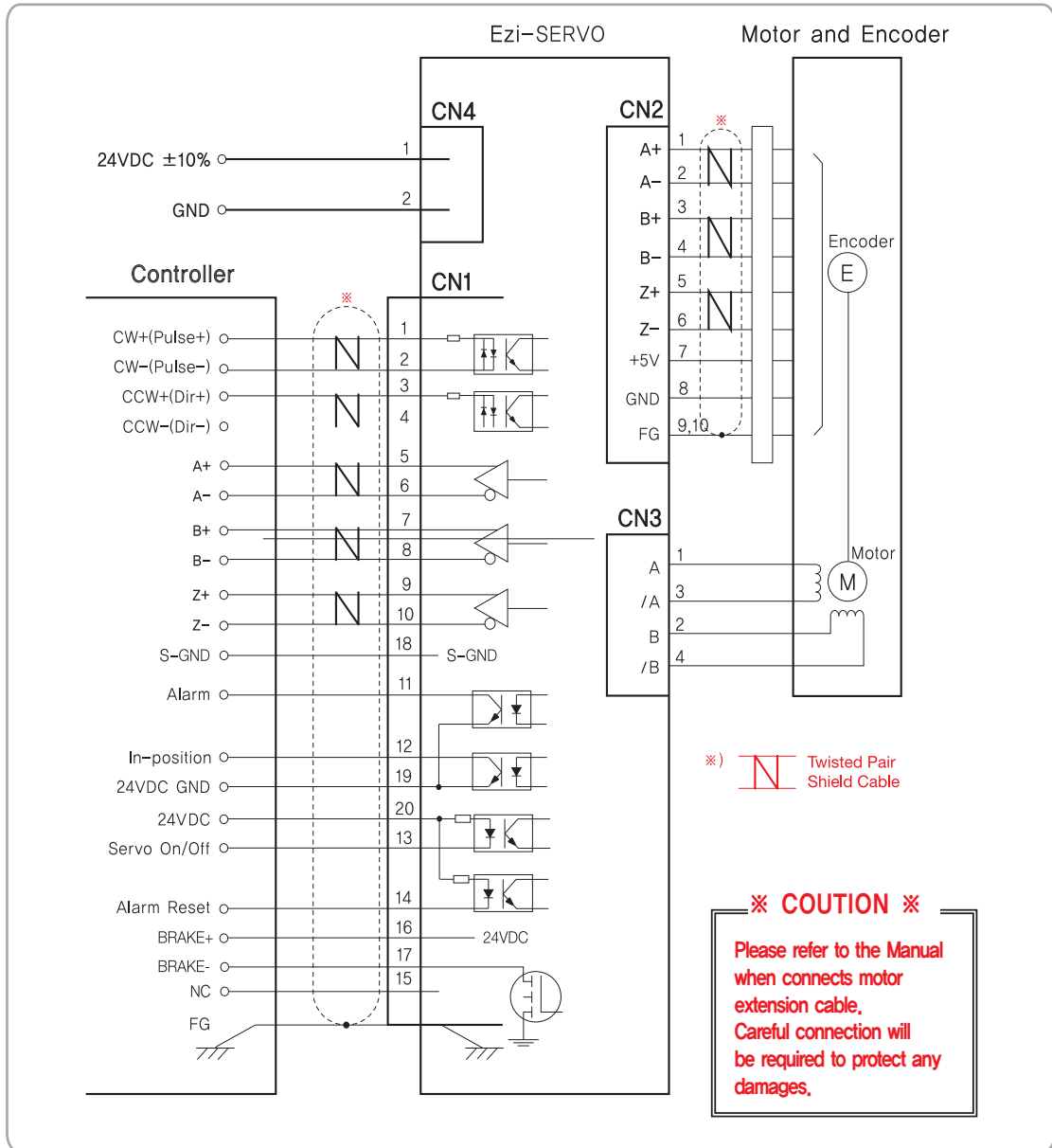

INPUT SIGNAL

Input signals of the drive are all hotocoupler protected, the signal shows the status of internal hotocouplers [ON: onduction], [OFF: on-conduction], ot isplaying the voltage levels f the signal.

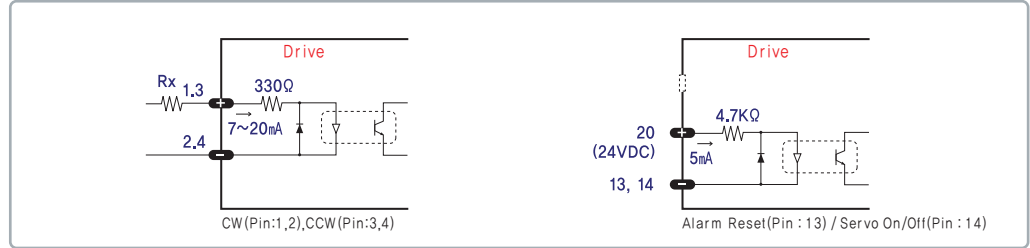

■ CW, CCW Input

This signal can be used to receive a positioning pulse command from a user host motion controller. The user can select 1-pulse input mode or 2-pulse input mode (refer to witch No.11, W1).The input schematic of CW, CCW is designed for 5V TTL level. When using 5V level as an input signal, the resistor Rx is not used and connect to he river directly. When the level of input signal is more than 5V, Rx resistor is re-quired, of the resistor is absent, the drive will be amaged! If the input signal level is 12V, Rx value is 2,2kohm and 24V, Rx value is .77kohm.

Alarm Reset

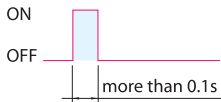

※ By setting thea larm reset nput signal [ON], ancel the Alarm output. Before ancel the Alarm output, have to remove the source of alarm.

■ Servo On/Off Input

This input can be used only to djust the position by manually moving the motor shaft from the load-side. By setting the signal [ON], the driver cuts off the power supply to the motor. Then, one can manually adjust output position. When setting the signal back to [OFF],the driver resumes the power to the motor and recovers the holding torque. When driving a motor, one needs to set the signal [OFF].

■ Alarm Reset Input

When a protection mode has been activated, a signal to this alarm reset input cancels the Alarm output.

OUTPUT SIGNALS

Output signals from the driver are hotocoupler protected: alarm, in-Position and the line Driver utputs (encoder signal). In the case of hotocoupler outputs, the signal indicates the status of internal hotocouplers ON: onduction], OFF: non-conduction], not isplaying the voltage levels of the signal..

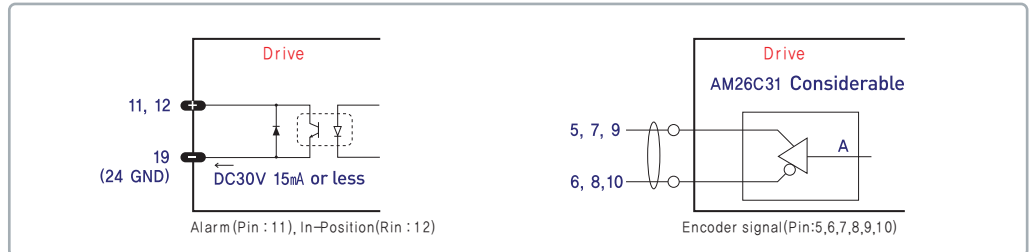

■ Alarm Output

The Alarm output indicates [ON] when the driver is in a normal operation. If a protection mode has been activated, it goes [OFF].A host controller needs to detect this signal and stop sending a motor driving command. When the driver detects an abnormal operation such as overload or over current of the motor, it sets the Alarm output to [OFF], flashes the Alarm LED, disconnect the power to a motor and stops the motor simultaneously.

[Caution] Only at the Alarm output port, the photocoupler isolation is reverse. When the driver is in normal operation the Alarm out put is [ON]. On the contrary when the driver is in abnormal operation that start protection mode, the alarm output is OFF].

Motor Speed

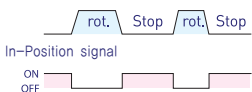

■ In-Position Output

In-Position signal is [ON] when positioning is completed. This signal is [ON] when the motor position error is within the value set by he witch SW4.

■ Encoder signal Output

The encoder signal is a line driver output, this can be used to confirm the stop position.

Controller Embedded Drive System Configurations

CONTROLLER EMBEDDED DRIVE SETTING AND OPERATING

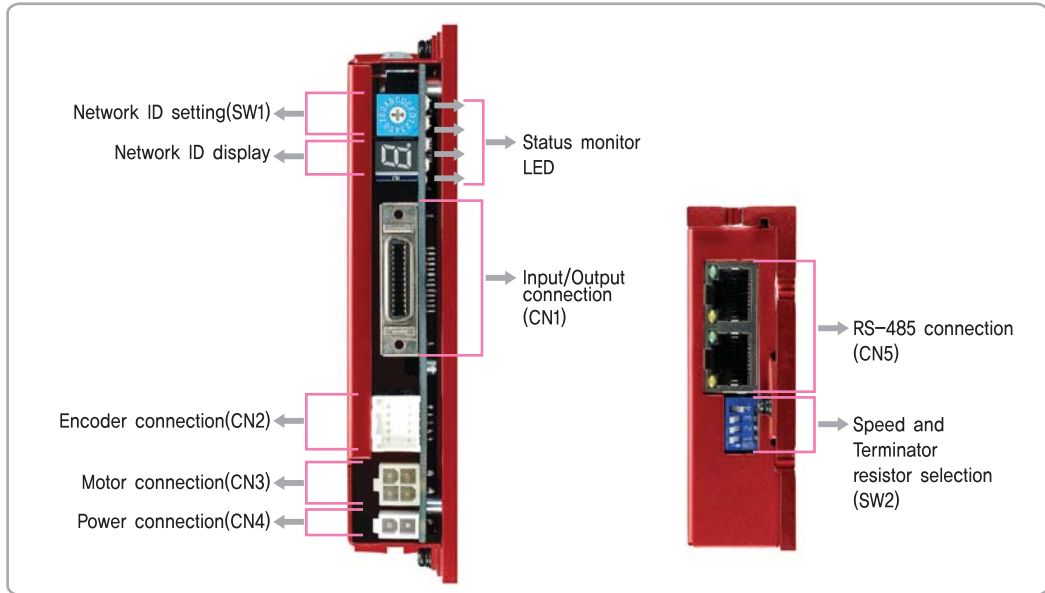

SETTING AND OPERATING

■ Status Monitor LED

Indication	Color	Function	ON/OFF Condition
PWR	Green	Power input indication	LED is turned ON when power is applied
INP	Yellow	Complete Positioning Motion	Lights On when Positioning error reaches within the preset pulse selected by rotary switch
SON	Orange	Servo On/Off Indication	Servo On : Lights On, Servo Off : Lights Off
ALM	Red	Alarm indication	Flash when protection function is activated (Identifiable which protection mode is activated by counting the blinking times)

• Protection functions and LED flash times

Times	Protection	Conditions
1	Over current	The current through power devices in inverter exceeds the limit value
2	Over speed	Motor speed exceed 3000rpm
3	Position tracking error	Position value is higher than specified value in motor stop status
4	Over load	The motor is continuously operated more than 5 second under a load exceeding the max,torque
5	Over temperature	Inside temperature of drive exceeds 55 °C
6	Over regenerated voltage	Back-EMF more high limit value ^{*1}
7	Motor Connect error	The power is ON without connection of the motor cable to drive
8	Encoder Connect error	Cable connection error with Encoder connector in drive
9	Low input voltage	Power source voltage is below limited value ^{*2}
10	Inposition error	After operation is finished,a position error occurs
11	System error	Error occurs in drive system
12	ROM error	Error occurs in parameter storage device(ROM)
14	Input voltage error	Power source voltage is higher than limited value ^{*3}

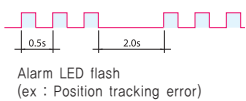

^{*1} Voltage limit of Back-EMF depends on motor model (Refer to the Manual)

^{*2} Low limit voltage value depends on motor model (Refer to the Manual)

^{*3} High limit voltage value depends on motor model (Refer to the Manual)

 SETTING AND OPERATING

2. Network ID selection switch(SW1)

Position	ID number	Position	ID number
0	0	8	8
1	1	9	9
2	2	A	10
3	3	B	11
4	4	C	12
5	5	D	13
6	6	E	14
7	7	F	15



* Maximum 16 axis can be connected in one network.

3. Encoder connector(CN2)

NO.	Function	I/O
1	A+	Input
2	A-	Input
3	B+	Input
4	B-	Input
5	Z+	Input
6	Z-	Input
7	5VDC	Output
8	5VDC GND	Output
9	Frame GND	----
10	Frame GND	----

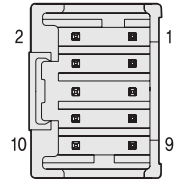

4. Speed and Terminator resistor selection switch(SW2)

The purpose of this is to setting the communication speed and connect a terminator resistor if drive is installed at the end of network.

SW 2,1 used for connecting the terminator resistor, SW 2,2~SW 2,4 used for setting speed as follows.

SW 2,1	SW 2,2	SW 2,3	SW 2,4	Baud rate[bps]
-	OFF	OFF	OFF	9600
-	ON	OFF	OFF	19200
-	OFF	ON	OFF	38400
-	ON	ON	OFF	57600
-	OFF	OFF	ON	115200 *1
-	ON	OFF	ON	230400
-	OFF	ON	ON	460800
-	ON	ON	ON	921600

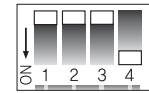

*1 : Default setting value
If SW2,1 is OFF, terminator resistor is disconnected.
If SW2,2 is ON, terminator resistor is connected.

5. Motor connector(CN3)



NO.	Function
1	A Phase
2	B Phase
3	/A Phase
4	/B Phase

6. Power connector(CN4)



NO.	Function
1	24VDC ±10%
2	GND

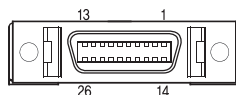

8. Input/Output signal(CN1)

NO.	Function	I/O
1	LIMIT+	Input
2	LIMIT-	Input
3	ORIGIN	Input
4	Digital In1	Input
5	Digital In6	Input
6	Digital In7	Input
7	Compare Out1	Output
8	Digital Out1	Output
9	Digital Out2	Output
10	Digital Out3	Output
11	Digital Out4	Output
12	Digital Out5	Output
13	Digital Out6	Output
14	Digital In2	Input
15	Digital In3	Input
16	Digital In4	Input
17	Digital In5	Input
18	Digital In8	Input
19	Digital In9	Input
20	Digital Out7	Output
21	Digital Out8	Output
22	Digital Out9	Output
23	BRAKE+	Output
24	BRAKE-	Output
25	24VDC GND	Input
26	24VDC	Input

*BRAKE function is optional.

Controller Embedded Drive Setting and Operating

SETTING AND OPERATING

7.RS-485 Communication connector(CN5)

There is converter for connecting PC.

1)RS-232 to RS-485

NO.	Function	NO.	Function
1	GND	6	Data-
2	GND	7	GND
3	Data+	8	GND
4	GND	LED 1, 3	Drive status
5	GND	LED 2, 4	Communication status

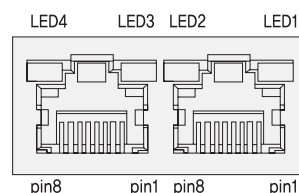

■ Connector for Cabling

ITEM		Specification	Maker
Signal Connector (CN1)	Connector	10126-3000PE	3M
	Shell	0326-52FO-008	3M
Encoder Connector (CN2)	Housing	51353-1000	MOLEX
	Terminal	56134-9000	MOLEX
Motor Connector (CN3)	Housing	5557-04R	MOLEX
	Terminal	5556T	MOLEX
Power Connector (CN4)	Housing	5557-02R	MOLEX
	Terminal	5556T	MOLEX

These connectors are serviced together with Ezi-SERVO Plus-R except when purchasing option cables.

Controller Embedded Drive System Configurations

CONTROLLER EMBEDDED DRIVE SYSTEM CONFIGURATIONS

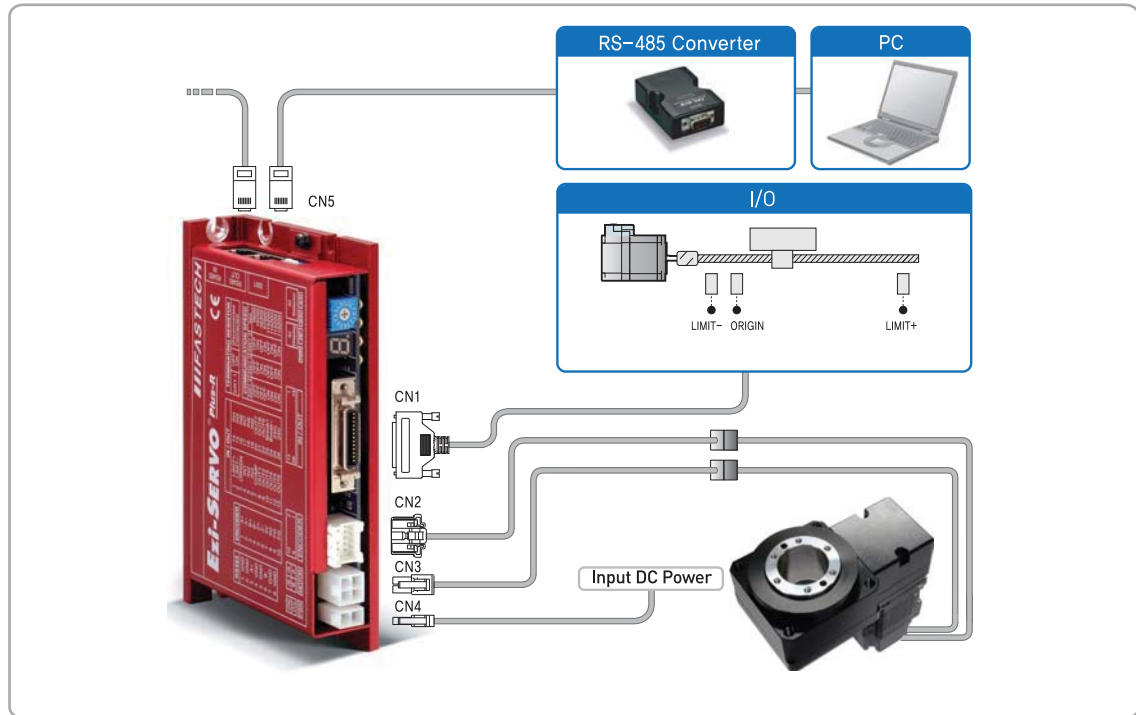

Type	Signal Cable	Encoder Cable	Motor Cable	Power Cable	RS-485 Cable
Standard Length	—	30cm	30cm	—	—
Max_Length	20m	20m	20m	2m	30m

■ Cable Option

1. Signal Cable

Available to connect between Control System and Ezi-SERVO Plus-R.

Item	Length [m]	Remark
CSV-R-S-□□□F	□□□	Normal Cable
CSV-R-S-□□□M	□□□	Robot Cable

□ is for Cable Length, The unit is 1m and Max, 20m length.

2. Encoder Extension Cable

Available to extended connection between Encoder and Ezi-SERVO Plus-R.

Item	Length [m]	Remark
CSV-O-E-□□□F	□□□	Normal Cable
CSV-O-E-□□□M	□□□	Robot Cable

□ is for Cable Length, The unit is 1m and Max, 20m length.

3. Motor Extension Cable

Available to extended connection between motor and Ezi-SERVO Plus-R.

Item	Length [m]	Remark
CSV-O-M-□□□F	□□□	Normal Cable
CSV-O-M-□□□M	□□□	Robot Cable

□ is for Cable Length, The unit is 1m and Max, 20m length.

4. Power Cable

Available to connect between Power and Ezi-SERVO Plus-R.

Item	Length [m]	Remark
CSV-O-P-□□□F	□□□	Normal Cable
CSV-O-P-□□□M	□□□	Robot Cable

□ is for Cable Length, The unit is 1m and Max, 2m length.

Controller Embedded Drive System Configurations

CONTROLLER EMBEDDED DRIVE SYSTEM CONFIGURATIONS

RS-485 Cable

Item	Length [m]	Remark
CGNR-R-0R6F	0,6	Normal Cable
CGNR-R-001F	1	
CGNR-R-1R5F	1,5	
CGNR-R-002F	2	
CGNR-R-003F	3	
CGNR-R-005F	5	

■ Option

6. FAS-RCR(RS-232C to RS-485 Converter)

Item	Specification
Comm.Speed	Max,115,2Kbps
Comm.Distance	RS-232C :Max,15m RS-485 :Max,1,2km
Connector Type	RS-232C : DB9 Female, RS-485 : RJ-45
Operating System	Windows 98/2000/XP/Vista
Dimension	50X75X23mm
Weight	38g
Power	Powered from PC (Usable for external DC5~24V)

RS-232C Cable

Item	Length [m]	Remark
CGNR-C-002F	2	Normal Cable
CGNR-C-003F	3	
CGNR-C-005F	5	

7. TB-Plus(Interface Board)

Available to connect more conveniently between Input/Output signal and Ezi-SERVO Plus-R,



Interface Cable

Available to Connect between TB-Plus Interface Board and Ezi-SERVO Plus-R,

Item	Length [m]	Remark
CIFD-S□□□F	□□□	Normal Cable
CIFD-S□□□M	□□□	Robot Cable

□ is for Cable Length, The unit is 1m and Max,20m length.

External Wiring Diagram

 CONTROLLER EMBEDDED DRIVE EXTERNAL WIRING DIAGRAM

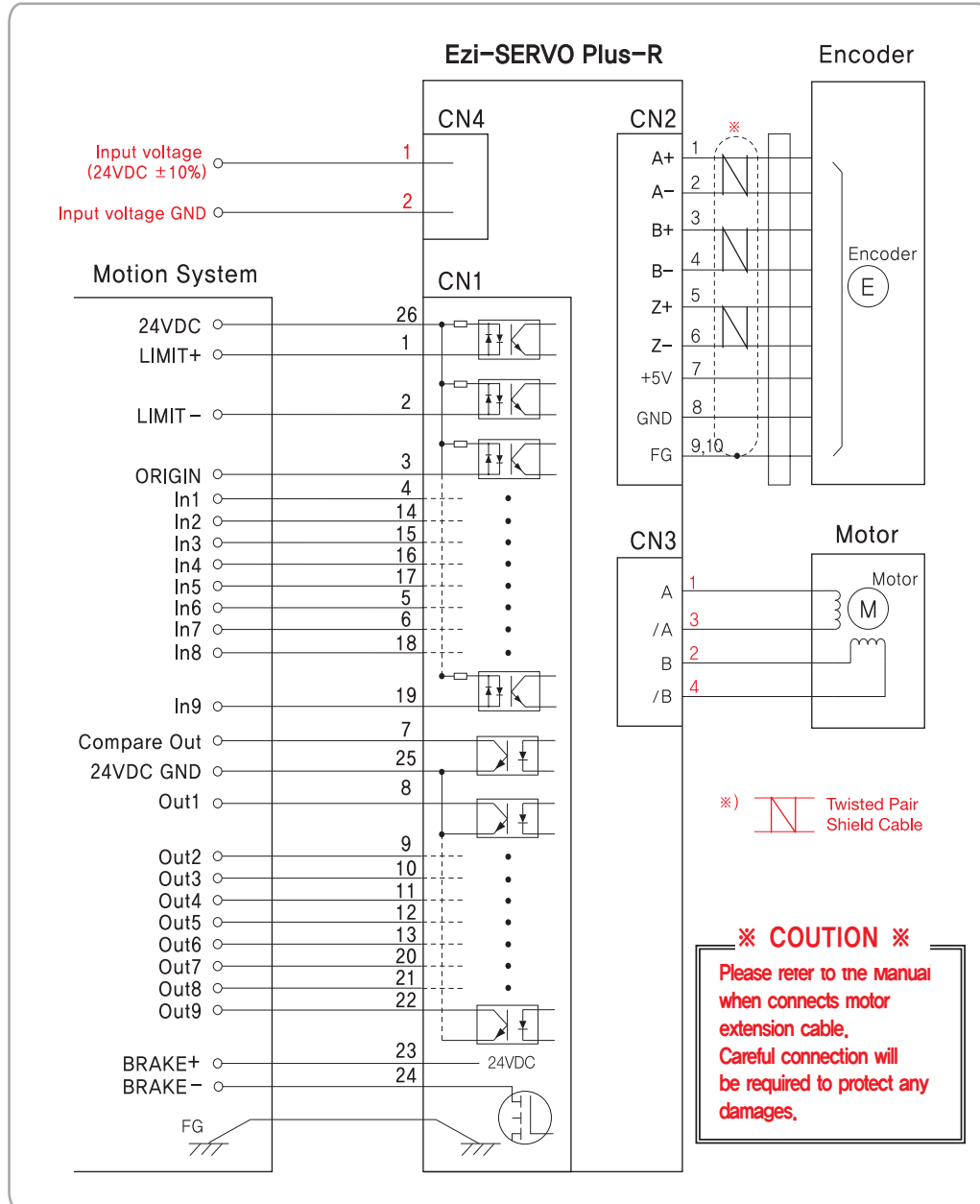

GUI (Graphic User Interface) Screen shot

CONTROLLER EMBEDDED DRIVE USER GUI

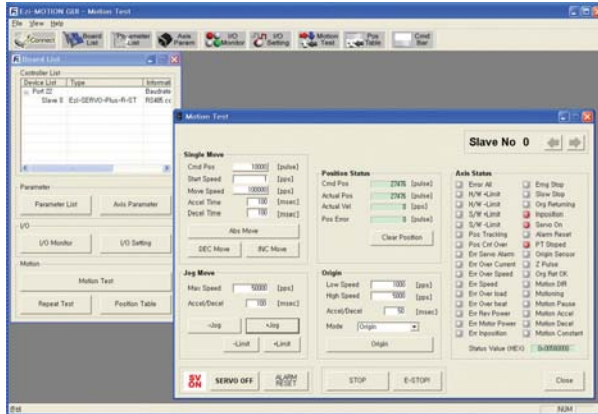

◆ Controller Lists and Motion Test

This screen display the controller list that connected to system, You can make a single move, jog and origin command and also the motor status is displayed.

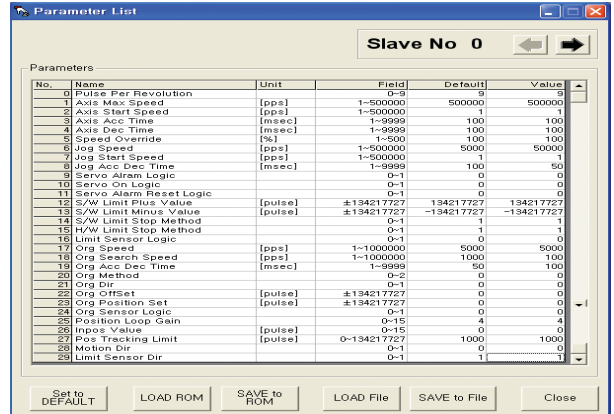

◆ Parameter List

All of the parameters are displayed and modified on this screen.

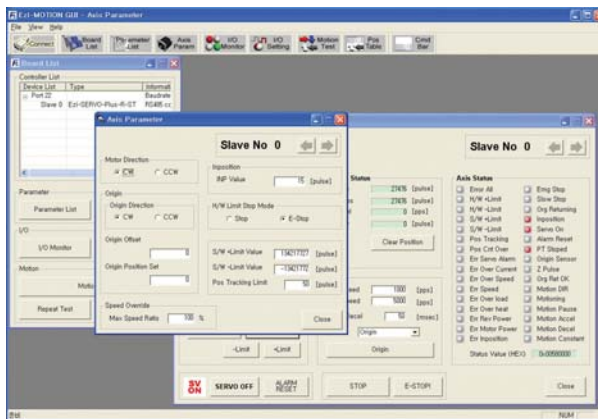

◆ Axis Parameter Setup

You can select various parameters that frequently used, (ex : sensor input logic)

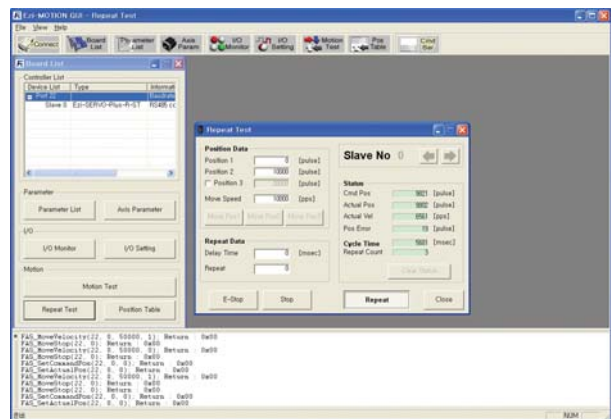

◆ Motion Repeat and Monitor Status

Target position, speed, delay time and repeat count are selected for repeat motion test, Motion library(DLL) is also displayed on screen.

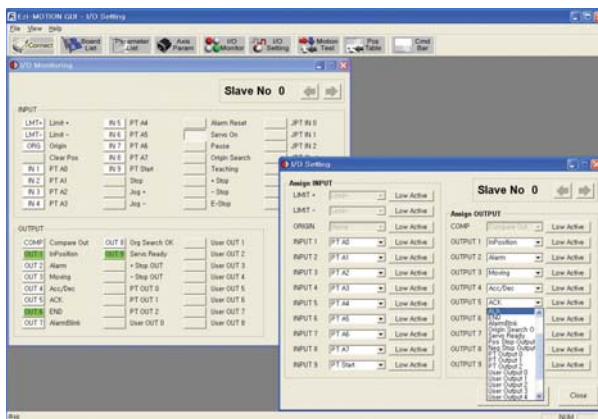

◆ I/O Monitoring and Setting

You can select various digital input and output signals of controller,

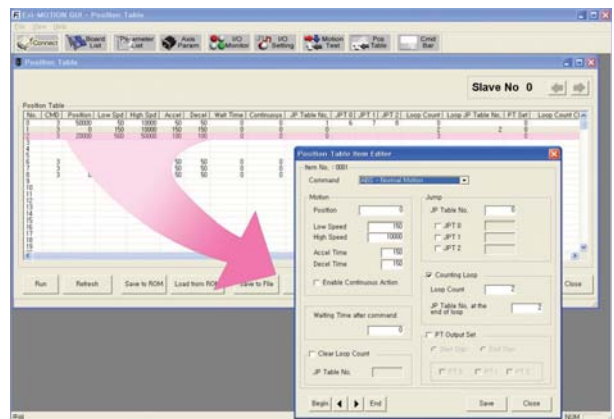

◆ Position Table

You can edit the position table and execute it, The position table data can be saved and loaded from Flash ROM and Windows file,

MEMO



FASTECH Co., Ltd.

Rm #1202, Bucheon Technopark 401 Dong, Yakdea-dong,
Wonmi-Gu, Bucheon-si, Gyeonggi-do, Rep. Of Korea (Zip)420-734
TEL : 82-32-234-6300,6301 FAX : 82-32-234-6302
E-mail : daniel@fastech.co.kr website: www.fastech.co.kr

FASTECH AMERICA LLC

811 E Plano Parkway, Suite 110A, Plano, TX 75074 USA
Toll Free: 877-905-4428 972-218-0210
Email: support@fastechamerica.com
website: www.fastechamerica.com